

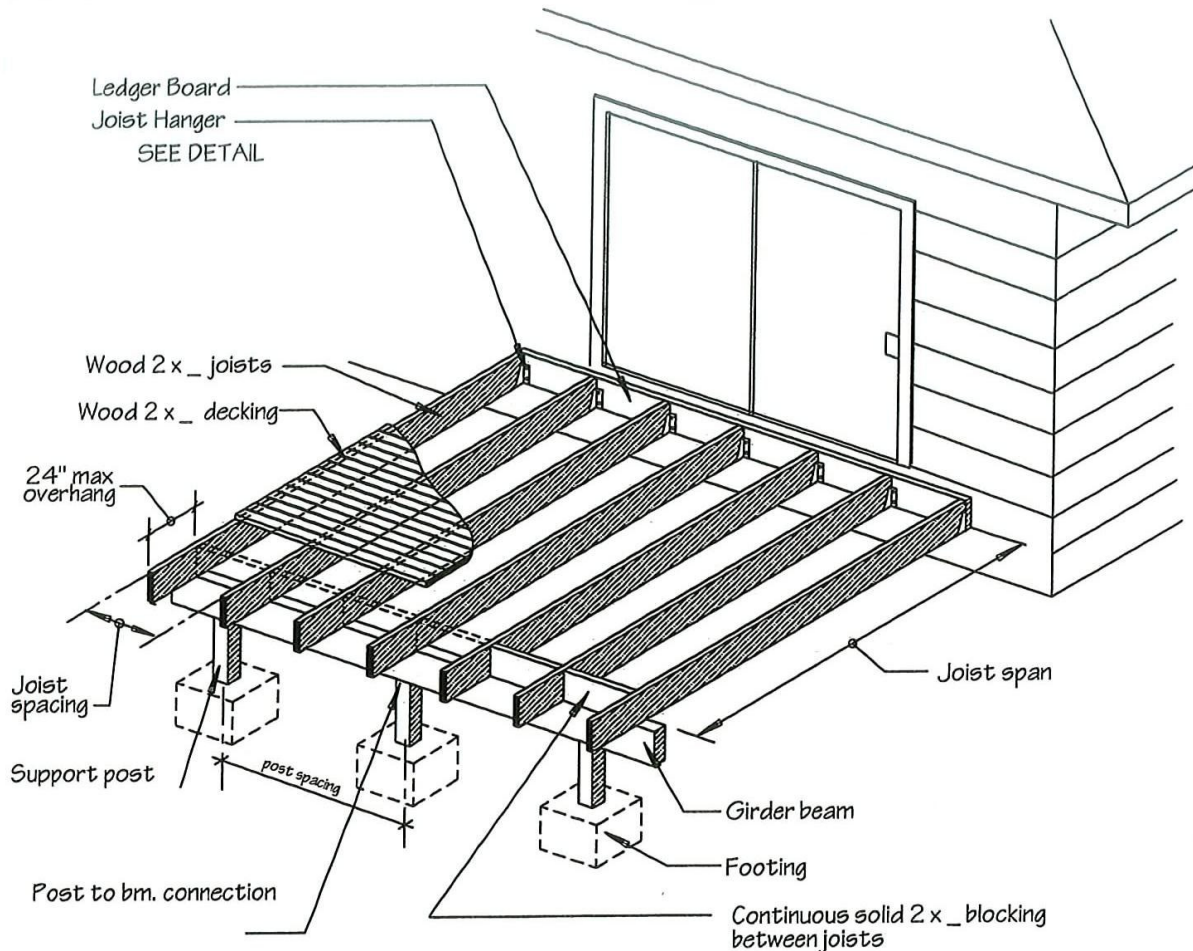

## BASIC DECKS



### DECK CONSTRUCTION NOTES:

1. The following illustrations & information may be used for decks whether or not they require a permit.
2. All wood must be pressure treated or naturally decay resistant.

1 TYPICAL DECK  
Page 1

### GENERAL INFORMATION:

1. CONSULT WITH YOUR LOCAL PLANNING DEPARTMENT REGARDING REQUIRED SETBACKS.
2. OBTAIN A BUILDING PERMIT BEFORE COMMENCING CONSTRUCTION.
3. THE INTENT OF THIS SHEET IS TO ADDRESS THE BASICS OF PRIVATE RESIDENTIAL DECKS CONSTRUCTION ONLY AND DOES NOT ADDRESS THE SUBJECT IN GREAT DETAIL. ADDITIONAL INFORMATION CAN BE FOUND AT YOUR LOCAL BUILDING DEPARTMENT, HOME IMPROVEMENT STORE, OR LIBRARY.

Planning & Community Development  
 1000 Laurel St. Milton, WA 98354-8850  
 Ph 253.922.8743 / Fax 253.922.3466

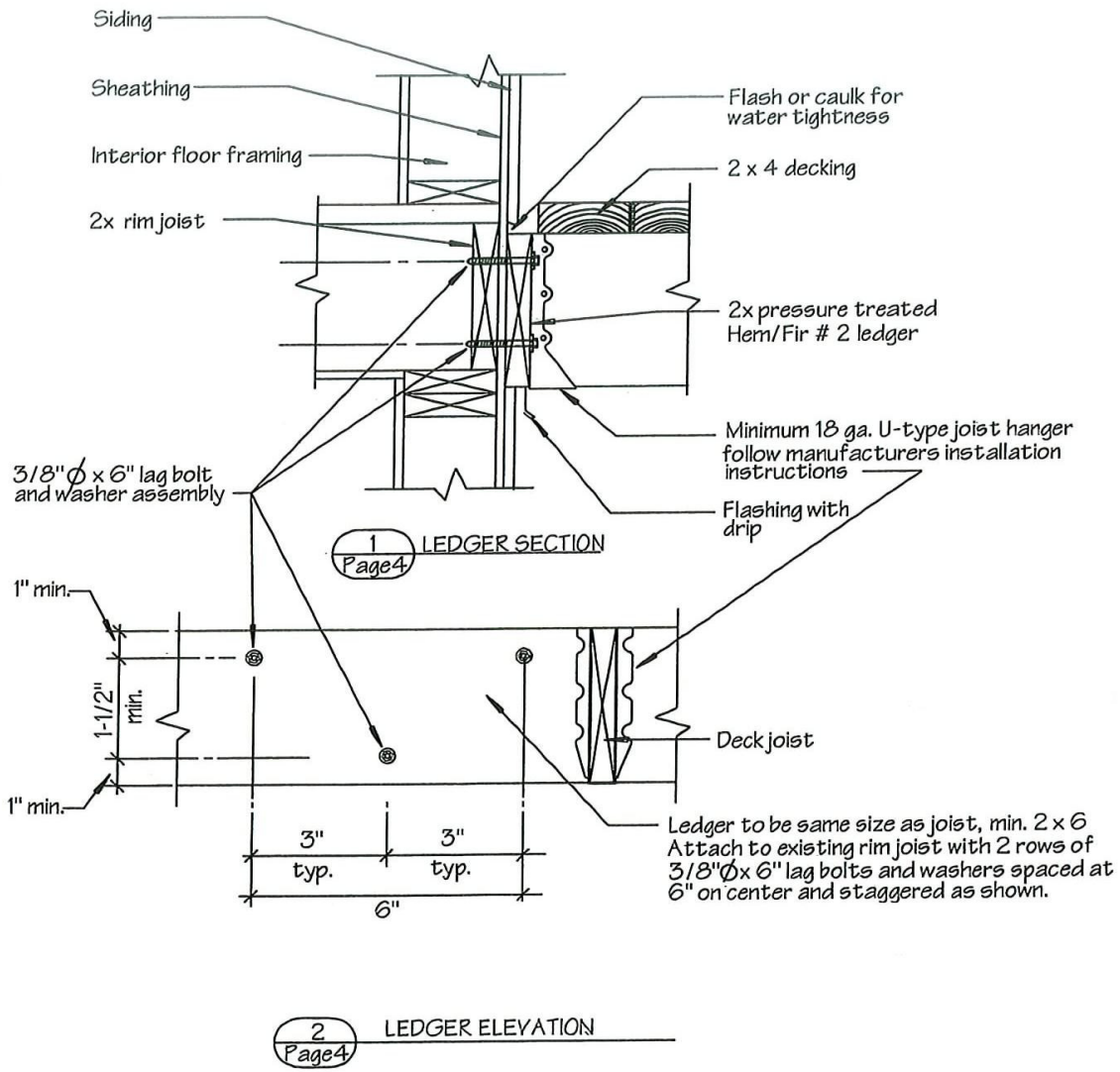

**GENERAL INFORMATION:**

1. CONSULT WITH YOUR LOCAL PLANNING DEPARTMENT REGARDING REQUIRED SETBACKS.
2. OBTAIN A BUILDING PERMIT BEFORE COMMENCING CONSTRUCTION.
3. THE INTENT OF THIS SHEET IS TO ADDRESS THE BASICS OF PRIVATE RESIDENTIAL DECKS CONSTRUCTION ONLY AND DOES NOT ADDRESS THE SUBJECT IN GREAT DETAIL. ADDITIONAL INFORMATION CAN BE FOUND AT YOUR LOCAL BUILDING DEPARTMENT, HOME IMPROVEMENT STORE, OR LIBRARY.